

Federkontakt / Spring Contact – UEFK-DB-100-01

Material (Material)
Kolben: gehärtetes Beryllium-Kupfer, vergoldet <i>(Plunger: Hardened Beryllium-Copper, Gold plated)</i> Stifthülse: Phosphor Bronze, Nickel beschichtet <i>(Barrel: Phosphor Bronze, Nickel plated)</i> Feder: Federstahl <i>(Spring: Music wire)</i> Beschichtung: vergoldet, Nickel beschichtet <i>(Plating: Gold plated, Nickel plated)</i> Hülse: Nickel Silber <i>(Receptacle: Nickel Silver)</i>
Elektrische Spezifikation (Electrical specification)
Nennstrom: 6 A <i>(Rated current: 6 A)</i> Kontaktwiderstand: < 50 mΩ <i>(Contact resistance: < 50 mΩ)</i>
Mechanische Spezifikation - untere Feder (Mechanical specification - bottom pin)
Minimum Raster: 2,54 mm <i>(Minimum Centers: 2,54 mm)</i> Max Hub: 2,54 mm <i>(Max. travel: 2,54 mm)</i> empfohlener Hub: 1,73 mm <i>(Recommended travel: 1,73 mm)</i> Federkraft: 110 g ± 20% bei Nennfederweglänge <i>(Spring Force: 110 g ± 20% @ working height)</i> Federvorspannung: 44 g <i>(Preload force: 44 g)</i> Anschluss: Crimp (RC100TW) <i>(Connection: Crimp (RC100TW))</i>
Bestellinformation (Order information)
Federkontakt (Spring Contact) Art No.: UEFK-DB-100-01 Hülse (Receptacle) Art No.: UEFK-RC100-TW

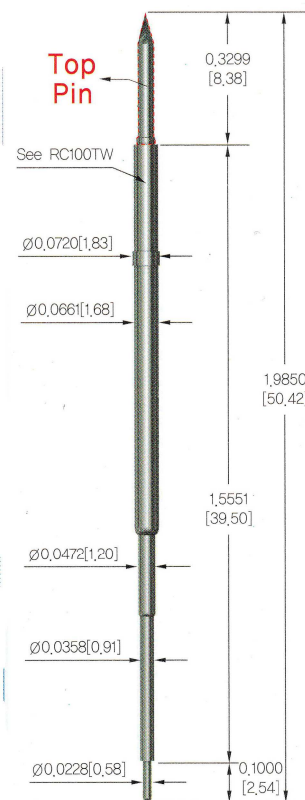

* A top pin is not included in the above model (one receptacle + one bottom pin)

Bottom PIN Spring Force		
Preload	Recommended Travel	Full Travel
	0,0681inch 1,73mm	0,1000 inch 2,54mm
1.5 ounces	3.9 ounces	5.0 ounces
44g	110g	141g

In Verbindung mit der UEFK-SP-100-Serie
(To be used with the UEFK-SP-100 Series)

RC100TW

Crimp Style Receptacle
: Nickel Silver / No Finish
 Mounting Hole Dia.:
 0,067 / 0,069 [1,70 / 1,75]
 Wire : AWG30

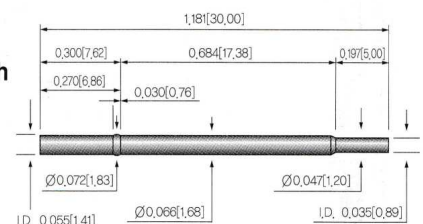

Manufactured by **LEENO**

Änderungen und Irrtümer vorbehalten. Angaben in Millimeter inch(mm) / Specifications subject to change without notice. Dimensions in Millimeter inch(mm)